



HANDS ON LIFTS

LIFTS FOR LIFE

DUMBWAITERS

DUMBWAITERS

Elegant and ultra-efficient... Meet the DUMBWAITER
that makes serving and cleaning up fast and effortless.

At Hands On Lifts, we strive to provide well-manufactured dumbwaiters that are aesthetically pleasing and ensure maximum functional efficiency and safety.

Our dumbwaiters can be used wherever there is a need to move small quantities of goods from one level to another and are perfect for restaurants, libraries, hotels and many other industries.

KEY DETAILS

CAPACITY	100kg - 500kg
SPEED	0.1m/s - 0.2m/s
TRAVEL HEIGHT	1m - 10m
MAX NUMBER OF FLOORS	8
DOOR ORIENTATION	Inline or opposite
DOOR OPERATION	Manual
CAR DOOR TYPES	None, bi-parting shutters
LANDING DOOR TYPES	Bi-parting shutters
MACHINE LOCATION OPTIONS	MRL (machine room less)
DRIVE TYPE	Positive drum drive
USE	Moving of goods only
FINISHES	Galvanized mild steel, powder coated mild steel, stainless steel
SERVING HEIGHT	Floor level or 800mm

PRODUCTS		DW1	DW2	DW3	DW4
CAPACITY (KG)		100	200	300	500
SHAFT SIZE (MM)	Width (SW)	900	1100	1300	1300
	Depth (SD)	900	1100	1300	1300
	Headroom (H)	3150	3350	3550	3550
	Serving Height (SH)	800	800	800	800
	Pit Depth (P)	0	0	0	0
CAR SIZE (MM)	Width (CW)	600	800	1000	1000
	Depth (CD)	600	800	1000	1000
	Car Height (CH)	600	800	1000	1000
	Door Opening Width (DOW)	600	800	1000	1000
	Door Opening Height (DOH)	600	800	1000	1000

*Other capacities, shaft and car sizes available – custom made to suit any requirement

BASIC LAYOUT

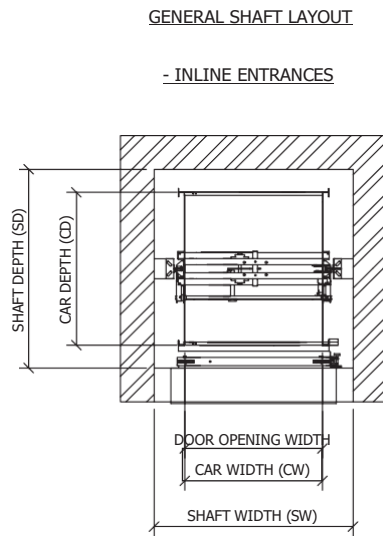
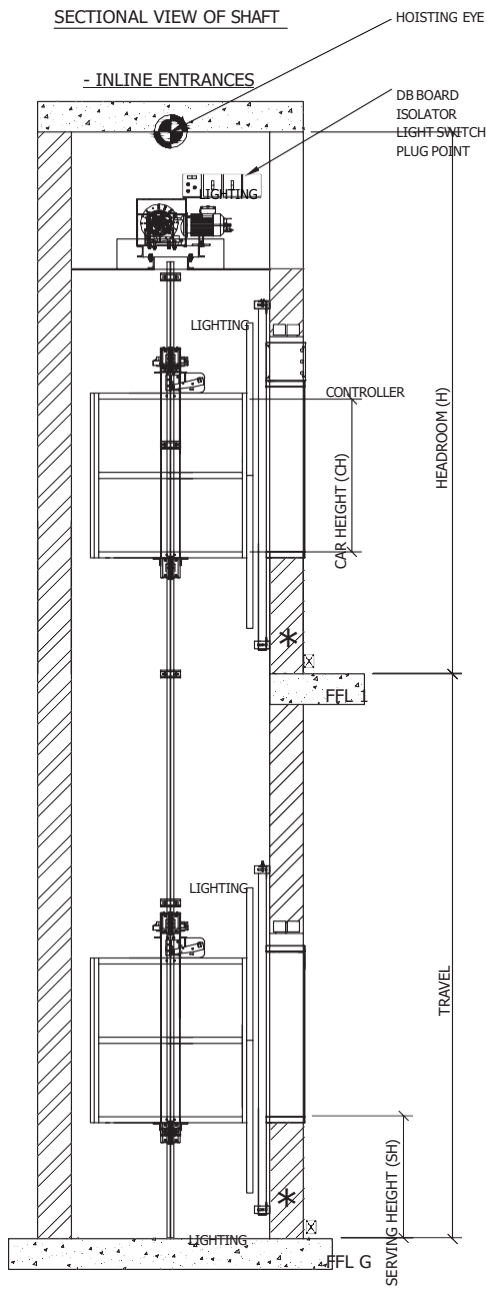

OPTIONAL EXTRAS

- _____
Arrival bell on car
- _____
Alarm bell for warning if doors have been open too long
- _____
Intercom between landings
- _____
Segmented display on landings
- _____
VVVF control
- _____
Shelf in car (Maximum load 100kg)





HANDS ON LIFTS
LIFTS FOR LIFE