

MAXIMUM LOAD
2000kg



HANDS ON LIFTS
LIFTS FOR LIFE

**GOODS
HOISTS**



GOODS HOISTS

Making life easier... A range of sturdy and reliable

GOODS HOISTS to swiftly and efficiently move products

from one level to the next.

Our goods hoists are designed, manufactured and installed in accordance with the SANS 1545-5 code. We believe in providing a well-manufactured, robust goods hoist that ensures maximum safety and functional efficiency. Our goods hoists are the perfect solution for moving goods in retail outlets, warehousing, manufacturing and all other fields of industry.

KEY DETAILS

CAPACITY	1000kg - 3000kg
SPEED	0.1m/s as standard, 0.2m/s if required
TRAVEL HEIGHT	1m – 12m
MAX NUMBER OF FLOORS	8
DOOR ORIENTATION	Inline or opposite
DOOR OPERATION	Manual
CAR DOOR TYPES	CAP gate, picket gate, eurofold
LANDING DOOR TYPES	CAP gate, eurofold
MACHINE LOCATION OPTIONS	MRL (machine room less), MRA (machine room above), MCBA (machine cabinet below adjacent)
DRIVE TYPE	Positive drum drive
USE	Moving of goods only
FINISHES	Galvanised mild steel, stainless steel grade 430 or 304

PRODUCTS		GH1	GH2	GH3	GH4	GH5
CAPACITY (KG)		1000	1500	2000	2500	3000
SHAFT SIZE (MM)	Width (SW)	2200	2200	2600	2600	3000
	Depth (SD)	1800	2100	2100	2600	3100
	Headroom (H) *L2	4100	4100	4100	4100	4100
	Pit Depth (P) *L3	1000	1000	1000	1000	1000
CAR SIZE (MM)	Width (CW)	1500	1500	1800	1800	2200
	Depth (CD)	1500	1800	1800	2300	2800
	Car Height (CH)	2000	2000	2000	2000	2000
	Door Opening Width (DOW)	1500	1800	1800	1800	2200
	Door Opening Height (DOH)	2000	2000	2000	2000	2000

*L2 - can be reduced by applying L2 rules | *L3 - can be reduced by applying L3 rules

*Other capacities, shaft and car sizes available – custom made to suit any requirement

BASIC LAYOUT

MCBA

PLAN VIEW OF MR ADJACENT SHAFT - IN-LINE ENTRANCES

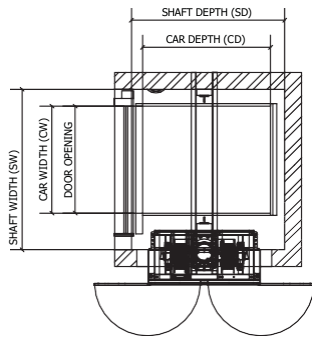

MRC

PLAN VIEW OF MRL SHAFT - IN-LINE ENTRANCES

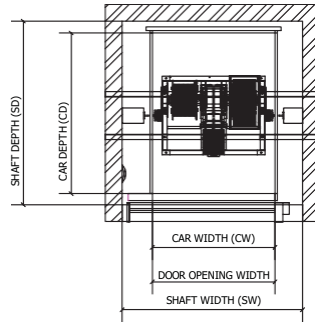

MRC

SECTIONAL VIEW OF MRL SHAFT - IN-LINE ENTRANCES

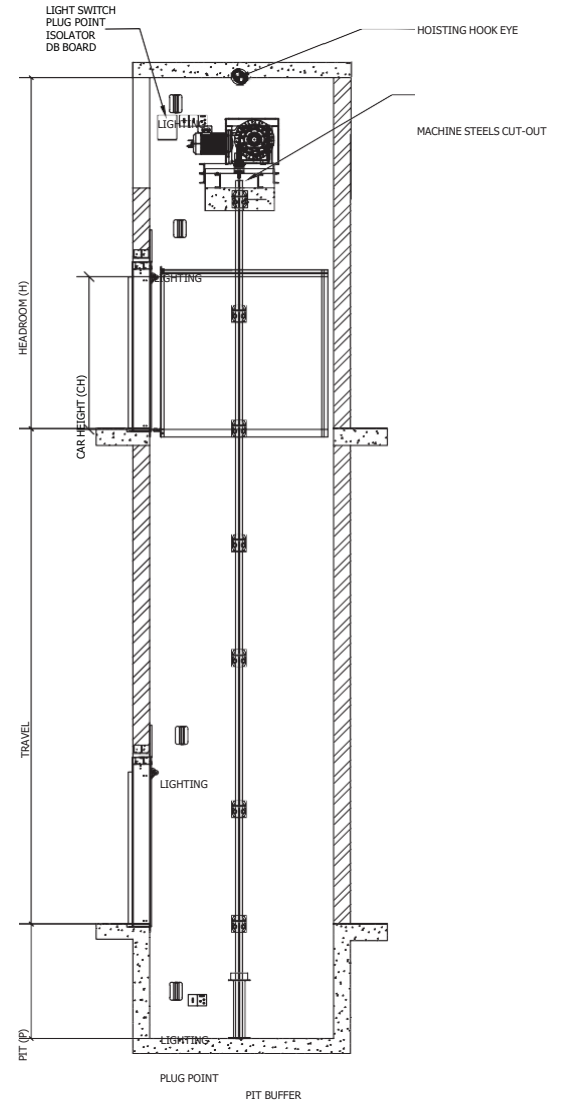

SECTIONAL VIEW OF MR ADJACENT SHAFT - IN-LINE ENTRANCES

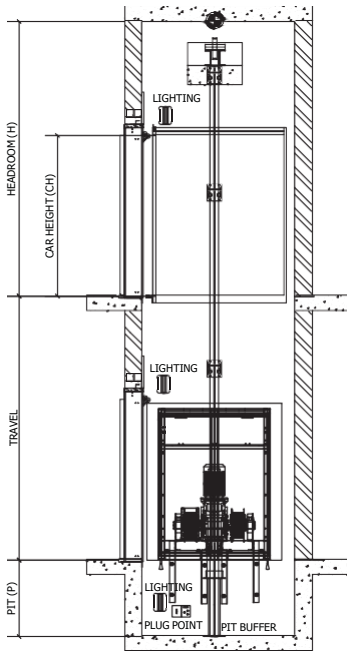

Built in accordance with
British Standard EN81-31
and SANS 1545-5

OPTIONAL EXTRAS

Arrival bell on car

Alarm bell for warning if doors have been open too long

Intercom between landings

Segmented display on landings

VVF control

Bumper rails

Meat rail

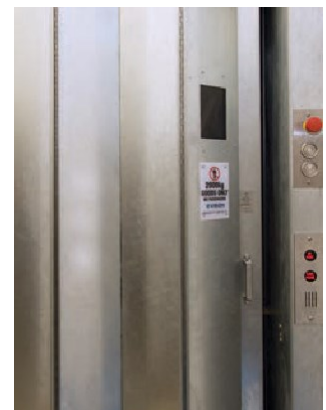



HANDS ON LIFTS
LIFTS FOR LIFE

Website: www.handsonlifts.co.za
Tel: (011) 918 7060
Cell: (082) 667 4964